

back side diaphragm seals, with flanged connection

MGS9/6



Diaphragm seals are designed to isolate the sensing element of pressure gauges, pressure switches and electronic pressure transmitter from process fluids which may be corrosive, viscous, sedimentous and/or with a high temperature. The diaphragm is leak proof tested to guarantee fill fluid separation from process fluid. Process side are ASME/EN 1092 flanged to suit application in chemical, petrochemical, water treatment and paper industries.

4.600 - MGS9/6

Instrument type	Minimum range	Maximum range	Notes
Bourdon tube, DS 4", 6" (100...150 mm)	0...10 psi (0...0,6 bar)	0...580 psi (0...40 bar)	Vacuum and compound gauges included
Diaphragm differential pressure gauges	0...100 InH ₂ O (0...250 mbar)	0...360 psi (0...25 bar)	Max static pressure 60 bar
Diaphragm pressure switches	0...15 psi (0...15 bar)	0...580 psi (0...40 bar)	Vacuum and compound gauges included
Pressure transmitters	0...40 InH ₂ O (0...100 mbar)	0...580 psi (0...40 bar)	Max static pressure 60 bar

Working temperature: -49...+302°F (-45°C...+150°C.)

Accuracy*: (add to instrument accuracy) ±0,5% for direct mounting; ± 1% for capillary mounting.

Instrument connection: AISI 316 st.st.

Diaphragm: AISI 316L st.st. (cod. **4**), Monel 400 (cod. **6**), Hastelloy C276 (cod. **9**), Tantalum (cod. **B**), Titanium (cod. **2**) and AISI 316L st.st. PTFE coated (cod. **8**)**.

Gaskets: PTFE (max. 250°C).

Flanged process connection: in AISI 316 st.st. (cod. **4**), AISI 316L st.st. (cod. **5**), AISI 316L st.st. PTFE coated (cod. **N**)**.

* at +68°F (20 °C) process temperature (or state when ordering)

Dimensions: DN 15...50, PN 6...40 EN 1092 step seal; 1/2"...2" class 150...600 RF as per ASME B16.5.

EN 1092 flanges finishing: type B1 (PN 2,5...40) = Ra 3,2...12,5 μm (cod. **RF7**); type B2 (PN 63...100) = Ra 0,8...3,2 μm (cod. **RF8**).

ASME flanges finishing: type RF = Ra 125...250 AARH (cod. **RF3**).

Filling liquid: silicon oil.

Studs, nuts: AISI 304 st.st.

** max. temperature 328°F (150 °C), with PTFE coating.

ASSEMBLING

All diaphragm seals are mounted on the instruments and fixed by an aluminium protection label. For applications with capillary: should diaphragm seal and instrument not be at the same level, instrument adjustment is required. (6 mt). (For use and installation, see data sheet "4")

D - Direct
T - Cooling extension
1 - Nude capillary AISI304, 236" max (6 mt max)
9 - Capillary AISI304 st.st., AISI304 st.st. armoured, 236" max (6 mt max)
6 - Capillary AISI316 st.st., AISI316 st.st. armoured, 236" max max (6 mt max)

OPTIONS

B - Silicon liquid "B", process fluid temp. -4°F...+482°F (-20°C...+250°C)
C - Silicon liquid "C", process fluid temp. +68°F...+644°F (+20°C...+340°C)
E - Fluorinated liquid "E", process fluid temp. -76°F...+302°F (-60°C...+150°C)
C05 - Helium Test (1)
E30 - Nace version bMR0103 (2) - MR0175 (ISO 15156) (3)
P15 - Studs, nuts and washers
TS4 - Washing plug (1)

(1) available only on some executions: contact our Technical Department.

(2) Monel 400 or Hastelloy C diaphragm.

(3) Hastelloy C process connection and diaphragm.

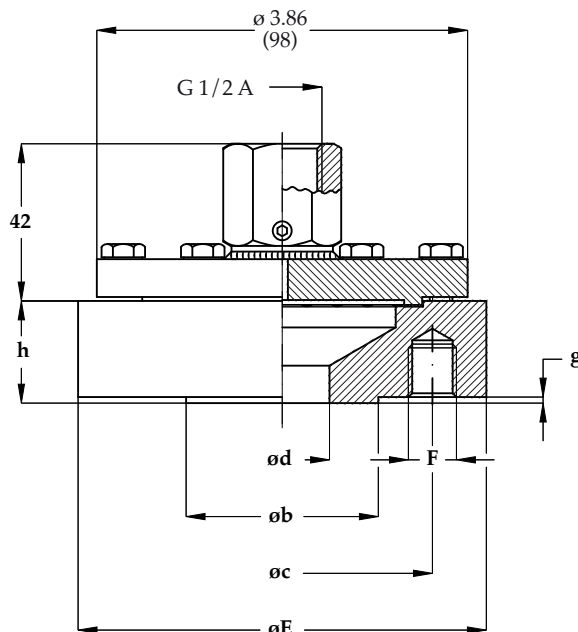

EN 1092 STANDARD

dimensions : mm

DN (1)	PN	Code	h	E	b	d	g	c	F	N (2)	L (3)
15	6	OO0	34	80	40	15	2	55	M10	4	70
15	16...40	OS0	27	95	45	15	2	65	M12	4	70
25	6	QO0	27	100	60	25	2	75	M10	4	70
25	16...40	QS0	27	115	68	25	2	85	M12	4	70
40	6	SO0	27	130	80	40	3	100	M12	4	70
40	16...40	SS0	27	150	88	40	3	110	M16	4	70
50	6	TO0	27	140	90	50	3	110	M12	4	70
50	16...40	TS0	27	165	102	50	3	125	M16	4	70

1) DN20, DN40 and over are available.

3) studs length

2) N° holes.

ASME STANDARDS

dimensions : inches

DN (1)	Class	Code	h	E	b	d	g	c	N (2)	L (3)	F
1/2"	150	4AA	1.33"	3.50"	34.9	0.59"	0.06"	2.37"	4	3.34"	1/2" 13UNC
1/2"	300	4BA	1.06"	3.74"	34.9	0.59"	0.06"	2.62"	4	3.34"	1/2" 13UNC
1/2"	600	4DA	1.90"	3.74"	34.9	0.59"	0.24"	2.62"	4	3.34"	1/2" 13UNC
1"	150	6AA	1.06"	4.25"	50.8	0.98"	0.06"	3.12"	4	3.34"	1/2" 13UNC
1"	300	6BA	1.49"	4.88"	50.8	0.98"	0.06"	3.5"	4	4.52"	5/8" 11UNC
1"	600	6DA	1.90"	4.88"	50.8	0.98"	0.24"	3.5"	4	4.52"	5/8" 11UNC
2"	150	BAA	1.06"	6"	92.1	1.96"	0.06"	4.74"	4	4.52"	5/8" 11UNC
2"	300	BBA	1.06"	6.49"	92.1	1.96"	0.06"	5"	8	4.52"	5/8" 11UNC
2"	600	BDA	1.90"	6.49"	92.1	1.96"	0.24"	5"	8	4.52"	5/8" 11UNC

1) 3/4", 1" 1/2 and over are available.

3) studs length

2) Nr. holes.

"HOW TO ORDER" SEQUENCE

Section	Model / material	Connection material	Diaphragm connection	Process	Flange finishing	Instrument connection	Assembling	Options
4	600	4, 5, N	4, 6, 9 B, 2, 8	OO0...TS0 4AA...BDA	RF3...RF8	41F - G 1/2 F	D, T 1, 9, 6	B...TS4